

# Marine Maintenance-Free Starting Battery



## BB N60 12V60Ah Marine Battery

- CQW Marine Battery
- Maintenance-free marine battery
- No need to refill electrolyte
- No need for equalisation charging
- CCS Certification
- Valve-regulated sealed structure

### SPECIFICATION:

Brand	BB	Authoritative Certification	CCS Certification
Model	6-CQW-60	Voltage	12V
Starting Current CCA (25 °C)	600A	Marine Cranking Amps MCA (25 °C)	780A
Dimension	228x170x195 (218) mm 8.97"x6.69"x7.67" (8.58")	Terminal Type	L
Package Dimensions	245x180x227 mm	Operating temperature range	10.5V - 14.4V
Weight (N / G)	14.10kg / 14.40kg	Cyclic Charge Voltage	20 °C - 25 °C

### Battery Dimension

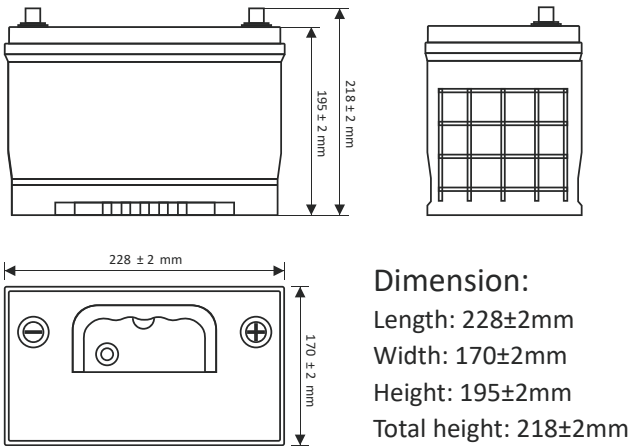

### Battery Characteristics

Starting Current CCA(25°C)	600A	
Reserve Capacity(RC)	67min	
Rated Capacity	20-hour rate(C20)	45Ah

### Stand terminals & Polarity

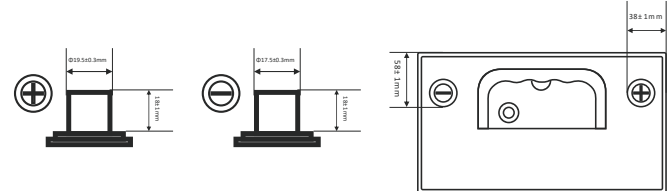

Accuracy of all technical data and information are provided to the best knowledge of the manufacturer. Properties, specifications and application parameters are subject to change without notice. The manufacturer does not undertake any liability of any kind whatsoever.

## Powering Your Voyage

Powering the World's Fleets. From small fishing boats to large commercial vessels, BB batteries provide the power you need. Our customizable solutions ensure that you get the perfect battery for your specific application.