

## A300V INTRINSICALLY SAFE MARINE RADIO



CCS Certificate



### 1. Helmet-Com Unit

- Hand free communication
- Bone connection microphone
- ATEX IIC T5



### 2. Push to Talk unit

- ATEX IIC T5
- IP67
- Adapts headset to two-way radio
- Large tactile "glove friendly" PTT button



### 3. Intrinsically Safe Marine Radio

- Ex ib IIB T4 Gb
- Compliant SOLAS Convention
- Passed CCS certification of China Classification Society
- Analog VHF Radio
- IP68

HZH MARINE GROUP CO.,LTD. supplies Smoke Diver Kit for the fire fighter's two-way portable radio communication. Smoke Diver Kit makes a perfect combination with fire fighter's breathing mask. This is the ideal communication solution for fire and rescue, special task operations on the vessel or offshore platform. We will be pleased to provide data sheet of complete items on request.

# MSC.338 (91) Regulation

For ships constructed on after 1 July 2014, minimum of two two-way portable radiotelephone apparatus for each fire party for fire-fighter's communication shall be carried on board. Those two-way portable radio-telephone apparatus shall be of an explosion-proof type or intrinsically safe. Ships constructed before 1 July 2014 shall comply with the requirements of this paragraph not later than the first survey after 1 July 2018.

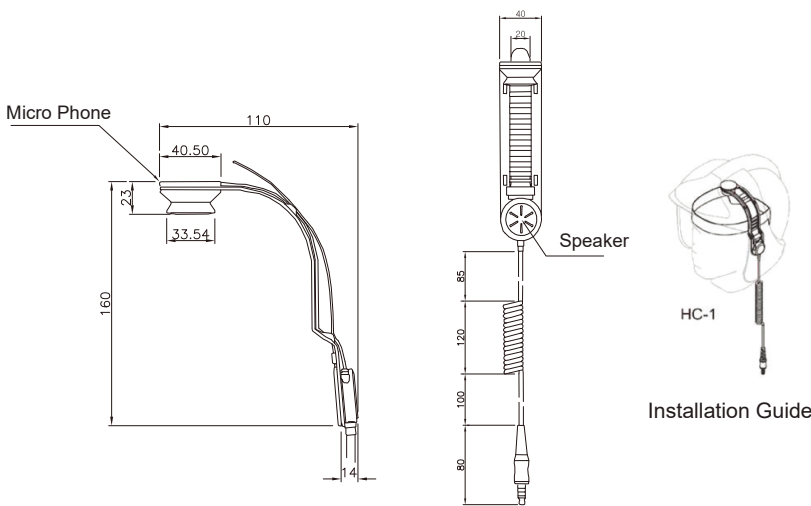

**Micro Phone**

110  
40.50  
2.3  
33.54  
1.60  
1.4

**Speaker**

40  
20  
85  
120  
100  
80

**HC-1**

**Installation Guide**

**Specification**

1. Weight : 64g
2. Operating Temperature : -25°C to +63°C
3. Mis : vibration sensor, noise attenuation 30dB
4. Speaker : 32ohm, air tube transfer
5. Cable : straight line (flame retardant): 4.2mm/750mm
6. Connector : 6pin quick plug-in type
7. Operation voltage : 2,5...10,0Vdc
8. Humidity : 95%RH, +63°C, 500 hours (continuous)

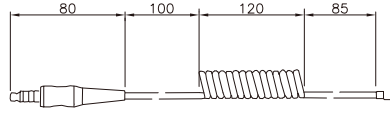
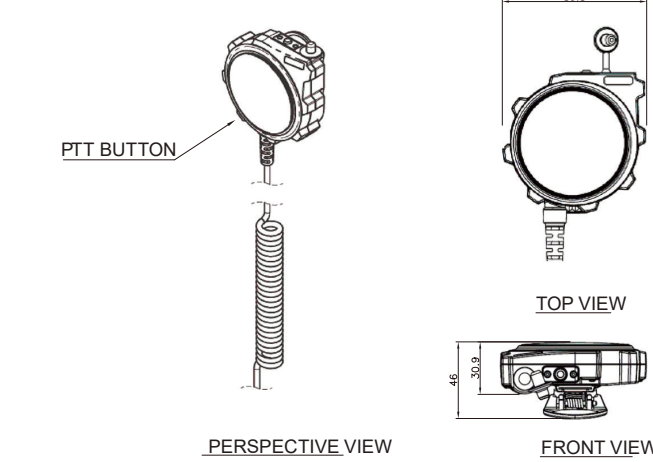
**PTT BUTTON**

**PERSPECTIVE VIEW**

**TOP VIEW**

69.8

**FRONT VIEW**

46  
30.9

**Specification**

1. Weight : 180g (with the Connector Cable)
2. Material : polycarbonate, silicone rubber
3. Cable : 4.3mm spring line (flame retardant)
4. Connector : 6 core quick plug-in type
5. Operating Temperature : -25°C to +60°C
6. Operation voltage : 3.7Vdc (M3-A/M3-W)
7. IP Grade : IP67
8. Humidity : 95%RH, +63°C, 500 hours (continuous)
9. Size : 87\*68\*42mm

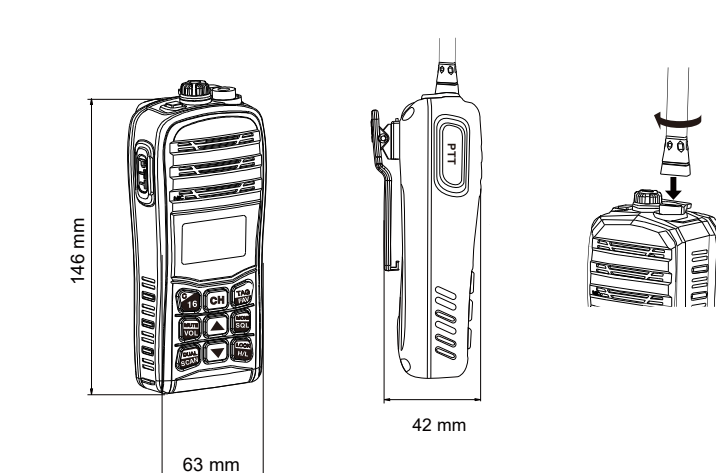

146 mm

63 mm

42 mm

**Specification**

1. Weight : 288g (with Rechargeable Battery)
2. Operating Temperature Range : -20°C to +40°C
3. Grade : IP68
4. Explosion proof level : Ex ib IIB T4 Gb
5. Transmitter power (Hi/Lo) (radiated) : 5W/1W

**CHANNELS AND FREQUENCIES**

1. Frequency Range : 156-163.425 MHz
2. Channels : International/Canada/Us Channel
3. Antenna resistance group : 50Ω
4. Debugging method : FM(16K0G3E)

**Passed CCS certification of China Classification Society**